

Installation Instructions

IMPORTANT NOTES

1. Failure to install, finish or maintain this product in accordance with applicable building codes, regulations, standards and James Hardie's written application instructions may lead to personal injury, affect system performance, violate local building codes, and void James Hardie's product warranty.
2. All warranties, conditions, liabilities (direct, indirect or consequential) and obligations whether arising in contract, tort or otherwise other than those specified in James Hardie's product warranty are excluded to the fullest extent allowed by law. For James Hardie's product warranty information and disclaimers about the information in this manual, see the section at the end of this manual
3. The builder must ensure the product meets aesthetic requirements before installation. James Hardie will not be responsible for rectifying aesthetic surface variations following installation.
4. Make sure your information is up to date. When specifying or installing James Hardie® products, ensure you have the current manual. If in doubt, or you need more information, visit www.jameshardie.com.au, www.scyon.com.au or Ask James Hardie™ on 13 11 03.

WARNING

DO NOT BREATHE DUST AND CUT ONLY IN WELL VENTILATED AREA

James Hardie products contain sand, a source of respirable crystalline silica which is considered by some international authorities to be a cause of cancer from some occupational sources. Breathing excessive amounts of respirable silica dust can also cause a disabling and potentially fatal lung disease called silicosis, and has been linked with other diseases. Some studies suggest smoking may increase these risks. During installation or handling:

- (1) work in outdoor areas with ample ventilation;
- (2) minimise dust when cutting by using either 'score and snap' knife, fibre cement shears or, where not feasible, use a HardiBlade® saw blade and dust reducing circular saw attached to a HEPA vacuum;
- (3) warn others in the immediate area to avoid breathing dust;
- (4) wear a properly-fitted, approved dust mask or respirator (e.g. P1 or P2) in accordance with applicable government regulations and manufacturer instructions to further limit respirable silica exposures. During clean-up, use HEPA vacuums or wet cleanup methods - never dry sweep. For further information, refer to our installation instructions and Material Safety Data Sheets available at www.jameshardie.com.au. FAILURE TO ADHERE TO OUR WARNINGS, MATERIAL SAFETY DATA SHEETS, AND INSTALLATION INSTRUCTIONS MAY LEAD TO SERIOUS PERSONAL INJURY OR DEATH.

JAMES HARDIE RECOMMENDED SAFE WORKING PRACTICES

CUTTING OUTDOORS

1. Position cutting station so wind will blow dust away from the user or others in working area.
2. Use a dust reducing circular saw equipped with HardiBlade® saw blade and HEPA vacuum extraction.

DRILLING/OTHER MACHINING

When drilling or machining you should always wear a P1 or P2 dust mask and warn others in the immediate area.

IMPORTANT NOTES

1. NEVER use a power saw indoors.
2. NEVER use a circular saw blade that does not carry the HardiBlade® logo.
3. NEVER dry sweep - Use wet suppression or HEPA vacuum.
4. NEVER use grinders.
5. ALWAYS follow tool manufacturers' safety recommendations.

P1 or P2 respirators should be used in conjunction with above cutting practices to further reduce dust exposures. Additional exposure information is available at www.jameshardie.com.au to help you determine the most appropriate cutting method for your job requirements. If concern still exists about exposure levels or you do not comply with the above practices, you should always consult a qualified industrial hygienist or contact James Hardie for further information.

STORAGE AND HANDLING

To avoid damage, all James Hardie building products should be stored with edges and corners of the product protected from chipping. James Hardie building products must be installed in a dry state and protected from weather during transport and storage. The product must be laid flat under cover on a smooth level surface clear of the ground to avoid exposure to water, moisture, etc.









SCYON™ LINEA™ WEATHERBOARD AND SCYON™ TRIM SIZES

Product	Length (mm)	Width (mm)	Thickness (mm)	End details	COVERAGE INFORMATION				
					Effective cover (mm)	No. of planks/ metre height	Mass kg/lin m	Mass kg/m²	Pallet weight (90/pack) kg
150mm Scyon Linea weatherboard	4200*	150	16	T & G	120	8.3	2.8	23.2	820
180mm Scyon Linea weatherboard	4200*	180	16	T & G	150	6.7	3.4	22.7	980
Scyon™ Axent™ Trim	2600	84	16	Square	N/A	N/A	1.6	N/A	N/A
Scyon™ Axent™ Trim	2600	100	16	Square	N/A	N/A	1.9	N/A	N/A
Scyon™ Axent™ Trim	4200	45	38	Square	N/A	N/A	1.7	N/A	N/A
Scyon™ Axent™ Trim	4200	84	38	Square	N/A	N/A	3.2	N/A	N/A

NOTES





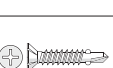

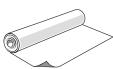

1. All dimensions and masses provided are approximate only and subject to manufacturing tolerances. Masses are based on equilibrium moisture content of product.
2. *Length is 4200mm plus 5mm for the tongue and groove (T & G) making the length 4205mm overall.
3. Refer to page 3 for details of the effective cover and lapped thickness of the cladding.

ACCESSORIES / TOOLS SUPPLIED BY JAMES HARDIE

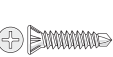
ACCESSORIES	DESCRIPTION	ACCESSORIES	DESCRIPTION
	Linea PVC starter strip PVC starter strip used to set out bottom edge of Scyon Linea weatherboard. 3.0m lengths		Linea aluminium internal corner mould Anodised aluminium extrusion used to create internal corners. 3.6m lengths
	Linea 150mm corner soaker Metal corner soaker for external corners available in either aluminium or stainless steel. Pack of 20, 170mm long.		Linea aluminium universal window adapter Aluminium window adapter used to finish the edge of weatherboards adjacent to windows. 3.7m lengths
	Linea 180mm corner soaker Metal corner soaker for external corners available in either aluminium or stainless steel. Pack of 20, 200mm long.		James Hardie joint sealant Paintable polyurethane sealant.
	Linea aluminium external slimline boxed corner Anodised aluminium extrusion used to create external boxed corners. 3.6m lengths		HardiBlade® saw blade Ø185 poly diamond blade, for fast, clean cutting of Scyon Linea cladding.
	Linea PVC box corner Z flashing PVC Z flashing used in conjunction with Linea trim to form external corners. 2.7m lengths		HardiDrive® screw 32mm long Class 3 galvanised screw for concealed fixing to 0.80 - 1.6mm BMT steel framing.

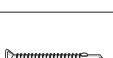
COMPONENTS NOT SUPPLIED BY JAMES HARDIE

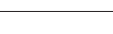
James Hardie recommends the following products for use in conjunction with its Scyon Linea weatherboard and Scyon™ Axent™ Trim. James Hardie does not supply these products and does not provide a warranty for their use. Please contact component the manufacturer for information on their warranties and further information on their products.

	Vapour permeable membrane Must have the following properties in accordance with AS/NZS 4200.1: Vapour barrier - low or medium Water barrier - high		Gun nails and nailers Suitable gun nails and nailers for concealed fixing to timber framing. Minimum nail length of 40mm is required.
	3.0mm dia drill bit For pre-drilling where required.		30mm Buildex FibreTEKS® Galvanised screw for concealed fixing to 0.55 - 0.75mm BMT steel framing.
	40 x 2.8mm fibre cement nails For concealed fixing Scyon Linea weatherboard and various accessories to timber framing as specified.		40mm special wing screw by TRI-FIX For concealed fixing to 0.55 - 1.2mm BMT steel framing. Available in galvanised and stainless steel.
	60 x 3.15mm bullet head nails For face fixing Scyon Linea weatherboard to timber framing as specified.		52mm special wing screw by TRI-FIX For face fixing to 0.55 - 1.2mm BMT steel framing. Available in galvanised and stainless steel.
	50 and 75 x 3.15mm bullet head nails For fixing Scyon™ Axent™ Trim to timber framing as specified.		Compound mitre saw Dust reducing compound mitre saw used with HardiBlade® saw blade. Makita: LS0714/LS1013/LS1212 Hitachi: C10F5B/C12F5B
	Vacuum extraction with HEPA filter Used with HEPA filter and paper bag for reduced dust exposure		

DESIGN

Compliance

All design and construction must comply with the appropriate requirements of the current Building Code of Australia (BCA), regulations and standards.

Responsibility

The specifier or other party responsible for the project must ensure that the details in this specification are appropriate for the intended application and that additional detailing is performed for specific design of any areas that fall outside the scope of this specification.

Slab and footings

The slab and footings on which the building is situated must comply with AS 2870 'Residential slabs and footings – Construction' and the requirements of the Building Code of Australia (BCA).

Ground clearances

Install James Hardie external cladding with a minimum 150mm clearance to the earth on the exterior of the building or in accordance with local building codes if greater than 150mm is required. Maintain a minimum 50mm clearance between James Hardie external cladding and roofs, decks, paths, steps and driveways.

Adjacent finished grade must slope away from the building in accordance with local building codes, typically a minimum slope of 50mm minimum over the first metre.

Do not install external cladding such that it may remain in contact with standing water.

NOTE

Greater clearance may be required in order to comply with termite protection provisions, see below.

Termite protection

The BCA specifies the requirements for termite barriers and must be complied with. Where the exposed slab edge is used as part of the termite barrier system, a minimum of 75mm of the exposed slab edge must be visible to permit ready detection of termite entry.

Moisture management

It is the responsibility of designer or specifier to identify moisture related risks associated with any particular building design. Wall construction design must effectively manage moisture, accounting for both the interior and exterior environments of the building, particularly in buildings that have a higher risk of wind driven rain penetration or that are artificially heated or cooled.

In addition all wall openings, penetrations, junctions, connections, window sills, heads and jambs must incorporate appropriate flashing and waterproofing. Materials, components and their installation that are used to manage moisture in framed wall construction must, at a minimum, comply with the requirements of relevant standards and the BCA.

Structural bracing

Scyon Linea weatherboard can be used to achieve wall bracing. For more information refer to the James Hardie Bracing Construction Design Manual.

Fire rated walls

Scyon Linea weatherboards clad walls can achieve fire ratings of 60/60/60 and 90/90/90 when constructed with additional fire rated linings as specified in the James Hardie fire and acoustically rated walls design manual and construction of fire and acoustically rated walls technical specification.

NOTE

Use 60 x 3.15 and 75 x 3.15mm corrosion resistant bullet head nails for concealed and face fixing respectively in fire rated applications.

FRAMING

General

Scyon Linea weatherboard may be specified for timber-framed or steel-framed structures. Stud spacings for Scyon Linea cladding for the wind load classifications of AS 4055 'Wind Loads for Housing' are given in Table 1.

TABLE 1

MAXIMUM STUD SPACING			
WIND CLASSIFICATION		STUD SPACING	
Non-cyclonic	Cyclonic	General areas of building (mm)	Within 1200mm of building edges (mm)
N1, N2, N3	C1	600	600
N4, N5	C2, C3	600	450
N6	C4	450	300

Timber framing

Dimensions

A 35mm minimum stud width is required.

Structural grade

Use only seasoned timber. Unseasoned timber must not be used because it is prone to shrinkage and can cause planks and frames to move.

Durability

'Timber used for house construction must have the level of durability appropriate for the relevant climate and expected service life and conditions including exposure to insect attacks or to moisture, which could cause decay.' Reference AS 1684.2 'Residential timber-framed construction'.

Frame construction

Use of timber framing must be in accordance with AS 1684 and the framing manufacturer's specifications. Stud spacings must be in accordance with Table 1.

NOTE: When using 70mm deep framing it is recommended that the Scyon Linea weatherboard be installed prior to plumbing, electrical and other services within the frame. This will prevent these services being damaged by fasteners used to install the Scyon Linea weatherboard.

Steel framing

Dimensions and gauge

A 35mm minimum stud width is required. Framing members must be in the range 0.55 to 1.6mm BMT (base metal thickness).

Durability

The steel framing must have the appropriate level of durability required to prevent corrosion.

Frame construction

Use of steel framing must be in accordance with AS 3623 and the framing manufacturer's specifications. Stud spacings must be in accordance with Table 1.

Special framing requirements

The following are special framing requirements for both timber and steel framing:

- Additional framing may be required at internal corners and sides of openings, see relevant details on the following pages.
- Extra depth lintels may be necessary for fixing of head flashing and trim. Lintels must be located in the frame flush externally to adequately support the head flashing and trim.
- Extra packers at external corners for use with Scyon Trim boxed corners.

Tolerances

Ensure frame is square and work from central datum line. Frames must be straight and true to provide a flush face to receive the Scyon Linea weatherboard. A suggested maximum tolerance of between 3mm and 4mm in any 3000mm length of frame will give best results. Scyon Linea weatherboard will not straighten excessively warped or distorted frames and any warping may still be visible after product is applied.

PREPARATION

Vapour permeable membrane

Vapour permeable membrane must be installed under Scyon Linea weatherboard in accordance with the AS/NZS 4200.2 'Pliable building membranes and underlays – Installation' and the manufacturer's specifications.

Vapour permeable membrane must have the following properties with AS/NZS 4200.1:

- Vapour barrier - low or medium
- Water barrier - high

The function of the vapour permeable membrane is to prevent moisture ingress by acting as a "drainage plane" whilst enabling water vapour buildup from inside the frame to escape.

Flashing

All wall openings, penetrations, intersections, connections, window sills, heads and jambs must be flashed prior to plank installation. See 'Moisture management' Section for requirements.

Accessories

Some Scyon Linea weatherboard accessories may require installation prior to fixing of the boards. Refer to the relevant details in this document.

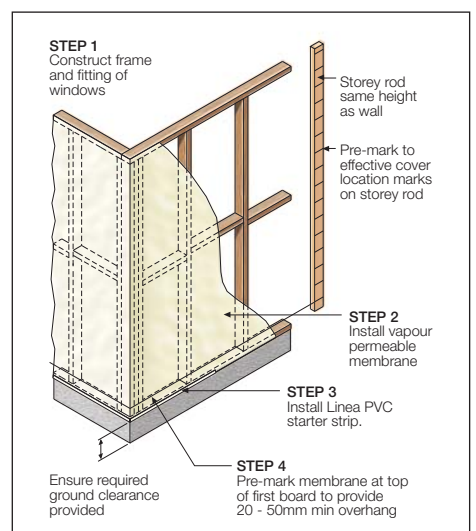

NOTES

1. Ensure all double studs are well nailed together, and flush at the outside face.
2. Generally external and internal corners have additional framing requirements and require that flashings and/or components are fitted prior to fixing the Scyon Linea weatherboard. Refer to the external and internal corner details.
3. Ensure aluminium corner accessories are installed prior to Scyon Linea weatherboard installation.
4. Alternative methods can be used to gauge the effective cover during installation e.g. marking corner moulds or using timber blocks cut to effective cover height to locate and support boards.

INSTALLATION

NOTE

You must ensure the product is of acceptable quality prior to installation, see Important Note 3. Install the cladding as detailed below around the building, joining the boards at the tongue and groove progressively.

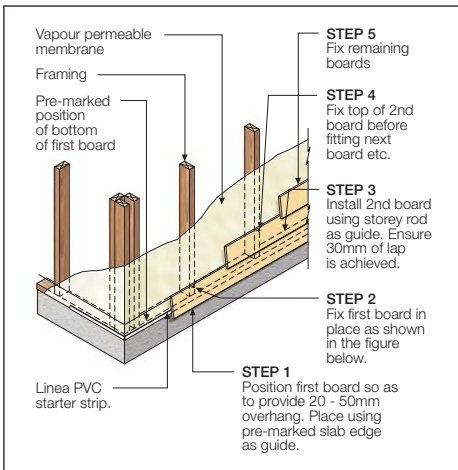

NOTES

1. Boards should be nailed to the studs starting from the centre of the board outwards.
2. Select an off-cut to start the second course at the corner so that joints are staggered.

SLAB / EAVE JUNCTION

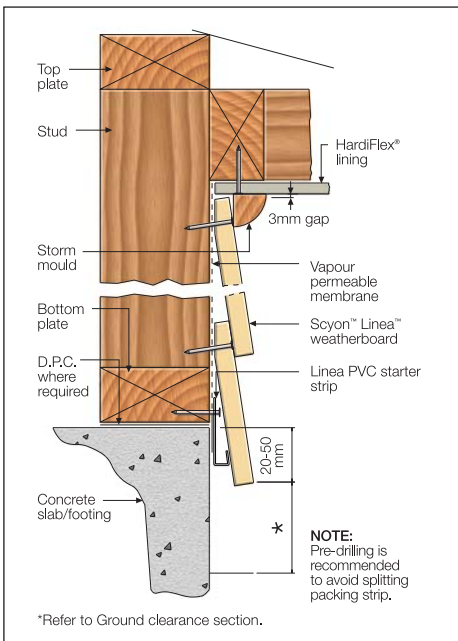

FIXING

Scyon Linea weatherboard is installed with 40 x 2.8mm fibre cement nails by concealed fixing as shown below. Suitable gun nails of 40mm minimum length can also be used.

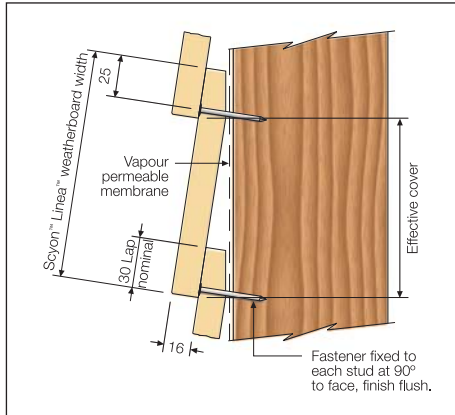

Face fixing must be provided for bracing applications as shown below.

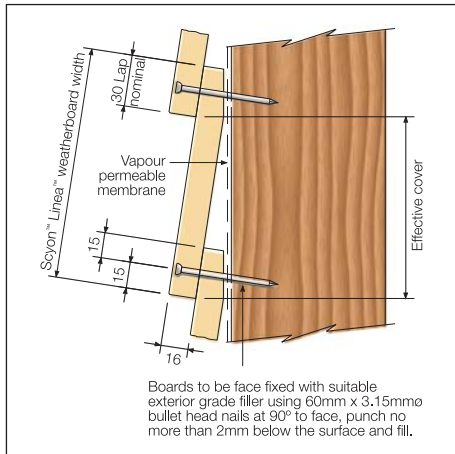

NOTES

1. Hold the board hard to the stud when fixing.
2. Face fixing may be added whenever site conditions create undue gaps between boards at laps. Alternatively corrosion resistant 25 mm brad nails can be used to minimise gaps by face fixing where required.
3. The minimum edge distance to the end of the board is 20mm for hand nailing and 50mm for gun nailing.
4. If fixing is to be carried out using a nail gun, ensure that the appropriate size and fastener durability is selected. Gun nailing is not recommended for face fixing applications.
5. Nail guns must be set to ensure that the nails are flush with the surface of the boards. Gun nails may require extra nailing by hand.
6. Face fixing method must be used if structural bracing required.
7. Longer fasteners may be required for fire rated applications, refer to the James Hardie Fire and Acoustically Rated Walls Design Manual.

FASTENERS

Fastener durability

Fasteners must have the appropriate level of durability required for the intended project. This is of particular importance in coastal areas, areas subject to salt spray and other corrosive environments.

Fasteners must be fully compatible with all other materials that they are in contact with to ensure the durability and integrity of the assembly.

Contact fastener manufacturers for more information.

Fasteners for timber

Hand nailing

Scyon Linea weatherboard must be fixed to timber framing with the types of nails shown in Table 2. Refer to Scyon™ Axent™ Trim Installation Instructions for trim fixing details.

TABLE 2

NAIL REQUIREMENTS FOR SCYON LINEA WEATHERBOARD	
CONCEALED NAILING	
40 x 2.8mm fibre cement nail	Class 3 minimum finished flush with board surface.
FACE NAILING	
60 x 3.15mm bullet head nails	Class 3 minimum nails may be driven through both thicknesses at board lap without pre-drilling. Stainless steel nails will require pre-drilling. Use a 3.0mm drill bit.

Gun nailing

A variety of gun nails are available for concealed nailing of Scyon Linea weatherboard using various guns. Nails must be a minimum of 40mm long, contact supplier for details.

NOTE

The minimum edge distance to the end of the board is 20mm and 50mm for hand and gun nailing respectively.

Fasteners for steel

Scyon Linea weatherboard must be fixed to 0.55 - 1.6mm BMT domestic type steel framing with the types of screws shown in Table 3.

TABLE 3

SCREW REQUIREMENTS FOR SCYON LINEA WEATHERBOARD	
CONCEALED SCREWING	
32mm HardiDrive® screw	Class 3 (hot-dipped galvanised) screw for concealed fixing to 0.80 - 1.6mm BMT steel framing.
30mm Buildex FibreTEKS	Galvanised screw for concealed fixing to 0.55 - 0.75mm BMT steel framing. Available in Class 3 (hot-dipped galvanised).
40mm special wing screw by TRI-FIXX	For 0.55 - 1.2mm BMT steel framing. Available in Class 3 (hot-dipped galvanised) and stainless steel.
32mm fibre cement screw DPT by South Pacific Fasteners	For 0.55 - 1.2mm BMT steel framing. Available in Class 3 (hot-dipped galvanised).
FACE SCREWING	
52mm special wing screw by TRI-FIXX	For 0.55 - 1.2mm BMT steel framing. Available in Class 3 (hot-dipped galvanised) and stainless steel.

Fasteners should be driven flush as shown below. The exception to this is where fasteners are exposed. In this case fasteners are typically punched and filled with a suitable exterior filler.

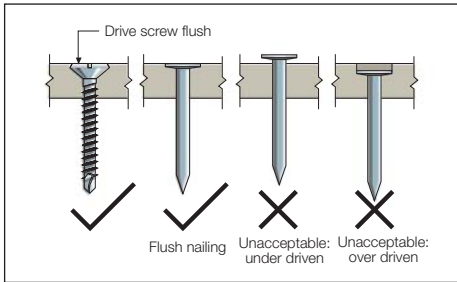

JOINTING

The ends of Scyon Linea weatherboard are jointed off-stud by means of the tongue-and-groove joint.

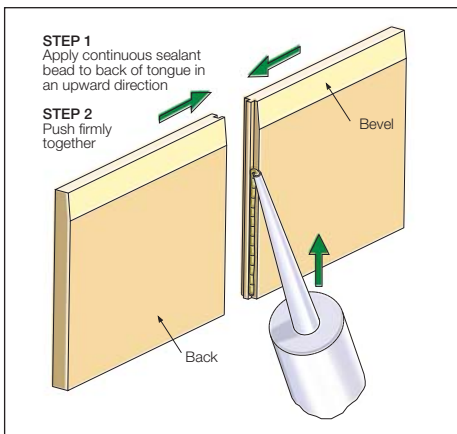
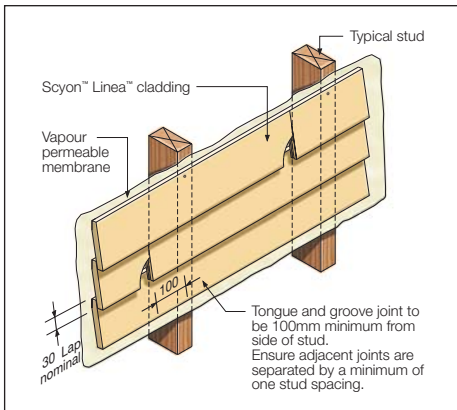

EXTERNAL CORNERS

Scyon™ Axent™ Trim external corner

NOTE: Refer to Scyon™ Axent™ Trim Installation Instructions for installation information.

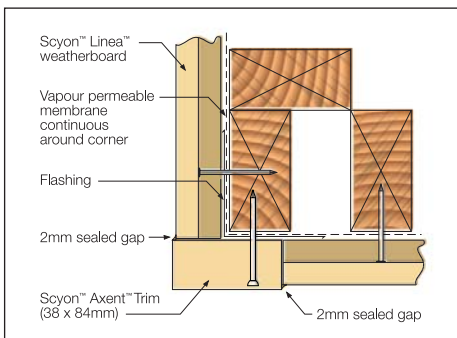

Slimline box corner

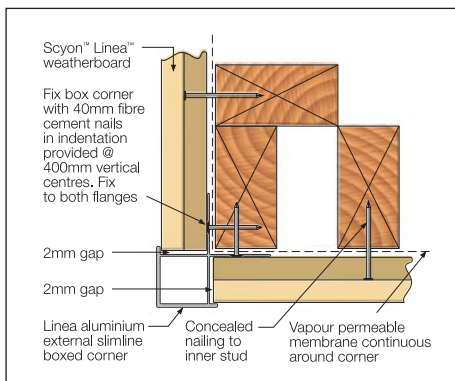
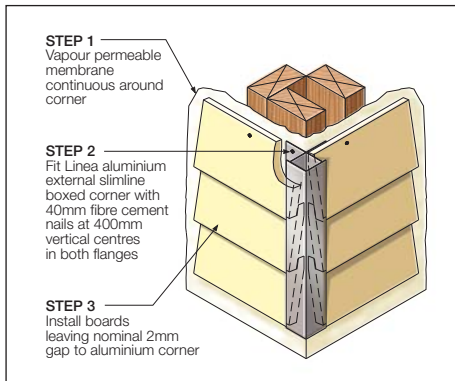

Corner soakers

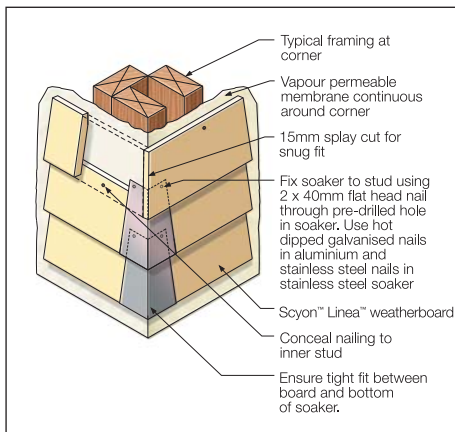

External mitre corner

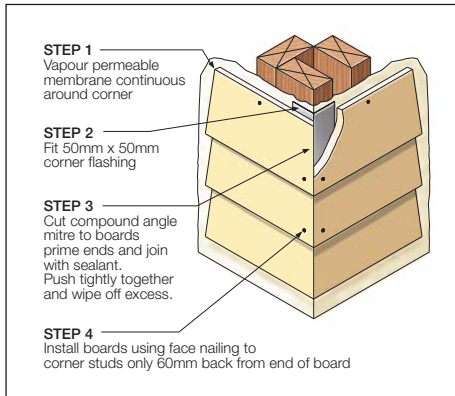

INTERNAL CORNERS

Scyon Trim internal corner

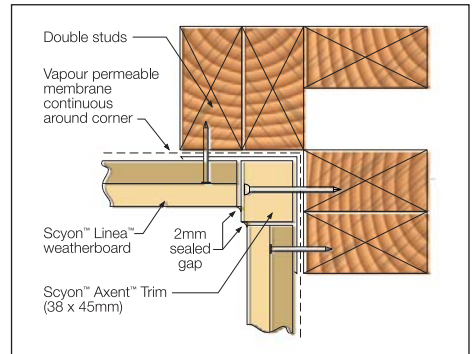

Internal corner mould

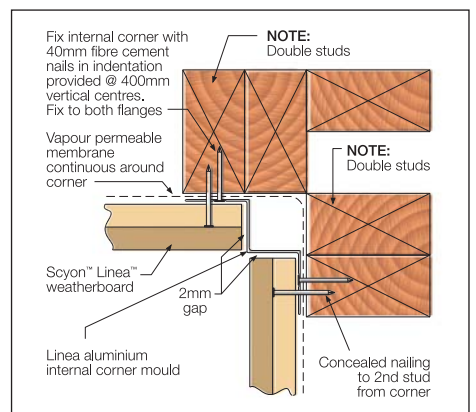
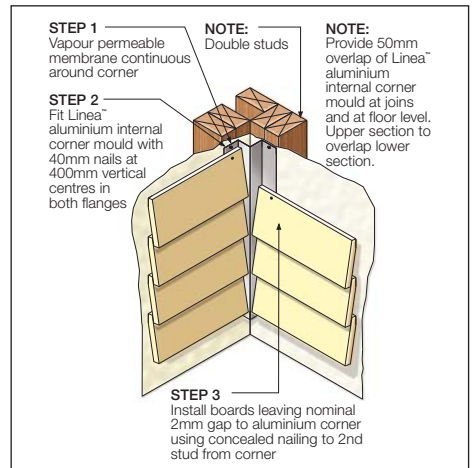

NOTCH AND SCRIBE

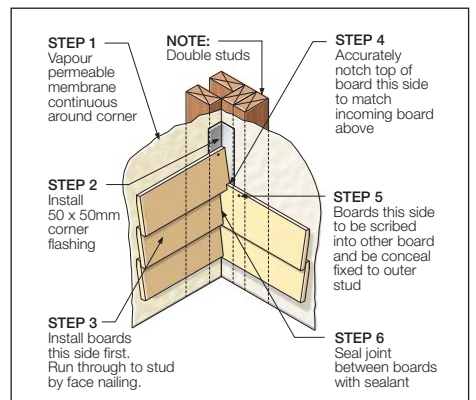

WINDOWS

Windows using Scyon™ Axent™ Trim

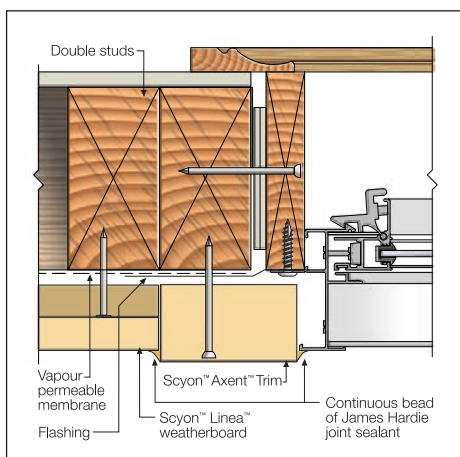
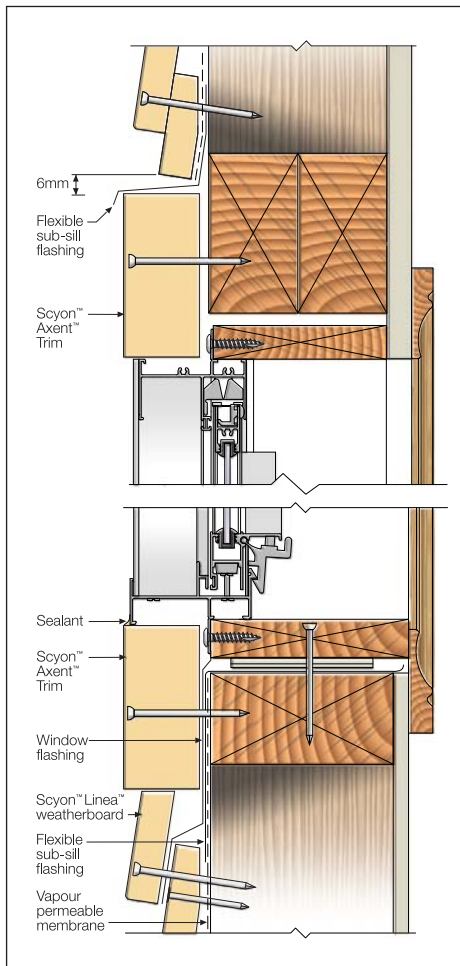

Windows using the aluminium window adapter

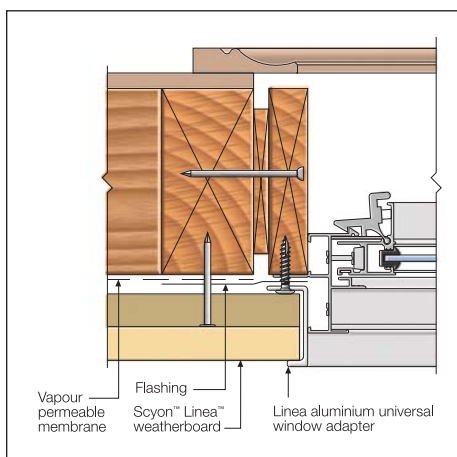
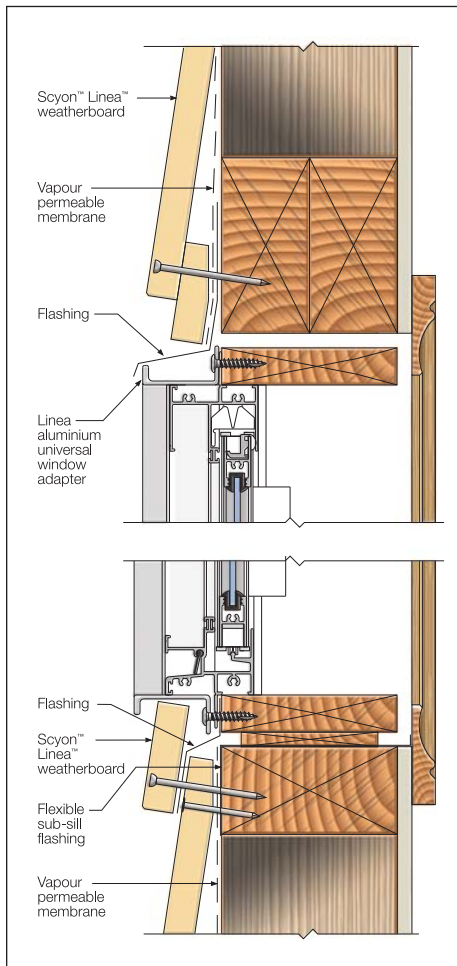

FINISHING

Preparation and priming

The Scyon Linea weatherboard and Scyon™ Axent™ Trim are pre-primed and must be dry before painting. Punch and fill all exposed nails a maximum of 2mm below the surface of the board. For screws, ensure the head of the screw is nominally 2mm below the surface of the board. Fill the hole with a suitable exterior grade filler, allow to cure and sand smooth. Priming of filled and sanded patches may be required in accordance with paint manufacturer's specifications.

NOTE: Care must be taken not to over-sand as it can affect the finish.

Sealants

Application and use of sealants must comply with manufacturer's instructions. Sealants, if coated, must be compatible with the paint system. James Hardie recommends the use of James Hardie joint sealant, which is a paintable polyurethane sealant.

Painting

Refer to the project specification for paint requirements. The Scyon Linea weatherboard and Scyon™ Axent™ Trim are pre-primed must be painted within 3 months of being fixed. James Hardie recommends the application of two coats minimum of a quality acrylic paint over the pre-primed boards in accordance with the paint manufacturer's specifications. Some environments require special coatings. Painting selection and specifications are dependant on the paint chosen. Refer to the paint manufacturer for information and details of their warranty.

Staining

Stains containing linseed oil are specifically designed for wood and may not be suitable for James Hardie cladding products, primed or unprimed. Semi-transparent stains can vary in uniformity of appearance depending on method of application and conditions and will require a high level of skill and craftsmanship to achieve a uniform appearance. Clear coats have not proven durable in exterior exposure and James Hardie considers them a maintenance item that may require application of a refurbishing sealer at regular intervals. James Hardie does not warrant the appearance or durability of semi-transparent stains and clear coats.

MAINTENANCE

The extent and nature of maintenance will depend on the geographical location and exposure of the building. As a guide, it is recommended that basic normal maintenance tasks shall include but not be limited to:

- Washing down exterior surfaces every 6-12 months*
- Re-applying of exterior protective finishes*
- Maintaining the exterior envelope and connections including joints, penetrations, flashings and sealants that may provide a means of moisture entry beyond the exterior cladding.
- Ensure clearances specified in this document is maintained.
- Cleaning out gutters, blocked pipes and overflows as required.
- Pruning back vegetation that is close to or touching the building.

*Refer to your paint manufacturer for washing down and recoating requirements related to paint performance.

PRODUCT INFORMATION

General

Scyon Linea weatherboard and Scyon™ Axent™ Trim are a reengineered concrete formulation utilising patented technology. The basic composition is Portland cement, ground sand, cellulose fibre, water and proprietary additives.

Scyon Linea weatherboard and Scyon™ Axent™ Trim are manufactured to AS/NZS 2908.2 'Cellulose-Cement Products Part 2: Flat Sheets'.

Scyon Linea weatherboard and Scyon™ Axent™ Trim are classified Type A, Category 3 in accordance with AS/NZS 2908.2.

For Material Safety Data Sheets (MSDS) visit www.jameshardie.com.au or Ask James Hardie™ on 13 1103.

Durability

Resistance to moisture/rotting

Scyon Linea weatherboard and Scyon™ Axent™ Trim has demonstrated resistance to permanent moisture-induced deterioration (rotting) by passing the following tests in accordance with AS/NZS 2908.2:

- Water permeability (Clause 8.2.2)
- Warm water (Clause 8.2.4)
- Heat rain (Clause 6.5)
- Soak dry (Clause 8.2.5).

Resistance to fire

Scyon Linea weatherboard and Scyon™ Axent™ Trim are suitable where non-combustible materials are required in accordance with C1.12 of the Building Code of Australia.

James Hardie building products have been tested by CSIRO and are classified as Group 1 material in accordance with Specification C1.10a of the BCA.

Scyon Linea weatherboard and Scyon™ Axent™ Trim have the following early fire hazard indices (tested to AS 1530 Part 3).

EARLY FIRE HAZARD INDICES

Ignition index	0
Flame spread index	0
Heat evolved index	0
Smoke developed index	0 - 1

NOTES: Zero is the best possible result. The range is 0 - 10, except Ignition Index which is 0 - 20.

Resistance to termite attack

Based on testing completed by CSIRO Division of Forest Products and Ensis Australia James Hardie building products have demonstrated resistance to termite attack.

Alpine regions

In regions subject to freeze/thaw conditions, James Hardie external cladding must be painted. In addition, the cladding must not be in direct contact with snow/or ice build up for extended periods, e.g. external walls in alpine regions subject to snow drifts over winter.

Tested to AS/NZS 2908.2 Clause 8.2.3

Ask James Hardie™
Call 13 11 03
www.jameshardie.com.au

WARRANTY

James Hardie Australia Pty Limited ("James Hardie") warrants to the first purchaser of the Product and the last purchaser prior to the installation of the Product for a period of 25 years from the date of purchase that Scyon™ Linea™ Weatherboard (the "Product") will be free from defects due to defective factory workmanship or materials and, subject to compliance with the conditions below, will be resistant to cracking, rotting, fire and damage from termite attacks to the extent set out in James Hardie's relevant published literature current at the time of installation. James Hardie warrants for a period of 12 months from the date of purchase that the accessories supplied by James Hardie will be free from defects due to defective factory workmanship or materials.

Nothing in this document shall exclude or modify any legal rights a customer may have under the Trade Practices Act or otherwise which cannot be excluded or modified at law.

Conditions of warranty

The warranty is strictly subject to the following conditions:

- a) James Hardie will not be liable for breach of warranty unless the claimant provides proof of purchase and makes a written claim either within 30 days after the defect would have become reasonably apparent or, if the defect was reasonably apparent prior to installation, then the claim must be made prior to installation;
- b) this warranty is not transferable;
- c) the Product must be installed and maintained strictly in accordance with the relevant James Hardie literature current at the time of installation and must be installed in conjunction with the components or products specified in the literature. To obtain copies of such literature contact Ask James Hardie™ on 13 11 03. Further, all other products, including coating and jointing systems, applied to or used in conjunction with the Product must be applied or installed and maintained strictly in accordance with the relevant manufacturer's instructions and good trade practice;
- d) the project must be designed and constructed in strict compliance with all relevant provisions of the current Building Code of Australia, regulations and standards;
- e) the claimant's sole remedy for breach of warranty is (at James Hardie's option) that James Hardie will either supply replacement product, rectify the affected product or pay for the cost of the replacement or rectification of the affected product;

- f) James Hardie will not be liable for any losses or damages (whether direct or indirect) including property damage or personal injury, consequential loss, economic loss or loss of profits, arising in contract or negligence or howsoever arising.

Without limiting the foregoing, James Hardie will not be liable for any claims, damages or defects arising from or in any way attributable to poor workmanship, poor design or detailing, settlement or structural movement and/or movement of materials to which the Product is attached, incorrect design of the structure, acts of God including but not limited to earthquakes, cyclones, floods or other severe weather conditions or unusual climatic conditions, efflorescence or performance of paint/coatings applied to the Product, normal wear and tear, growth of mould, mildew, fungi, bacteria, or any organism on any Product surface or Product (whether on the exposed or unexposed surfaces);

- g) all warranties, conditions, liabilities and obligations other than those specified in this warranty are excluded to the fullest extent allowed by law;
- h) if meeting a claim under this warranty involves re-coating of Products, there may be slight colour differences between the original and replacement Products due to the effects of weathering and variations in materials over time.

DISCLAIMER

The recommendations in James Hardie's literature are based on good building practice, but are not an exhaustive statement of all relevant information and are subject to conditions (c), (d), (f) and (g) above. Further, as the successful performance of the relevant system depends on numerous factors outside the control of James Hardie (eg quality of workmanship and design), James Hardie shall not be liable for the recommendations in that literature and the performance of the relevant system, including its suitability for any purpose or ability to satisfy the relevant provisions of the Building Code of Australia, regulations and standards.

For more information please Ask James Hardie™ on 13 11 03 or visit www.jameshardie.com.au or www.scyon.com.au

COPYRIGHT SEPTEMBER 2008
© JAMES HARDIE AUSTRALIA PTY LTD ABN 12 084 635 558
™ AND ® DENOTES A TRADEMARK OR REGISTERED MARK
OWNED BY JAMES HARDIE INTERNATIONAL FINANCE BV.
FibreTEKS® IS A REGISTERED TRADEMARK OF ITW BUILDEX